

# EPAL CP9 Pallet

1,140 x 1,140 mm



European Pallet Association e.V.



Safety and quality are of particular importance in the chemicals industry. Protecting employees, the environment and the load itself take priority. With the new quality-assured EPAL CP pallets, EPAL is closing a major gap in the chemicals industry's logistics chain. You can obtain EPAL CP pallets 1 - 9 from any one of the more than 1,500 licensed manufacturers and repairers. Supplier search under [www.epal.eu](http://www.epal.eu).

## Facts & figures

Materials: 24 boards of quality timber, 9 wood-chip or solid wood blocks, 102 nails. Produced according to the EPAL Technical Regulations.

Length	1,140 mm
Width	1,140 mm
Height	156 mm

## Markings



EPAL in oval on the right-hand corner block.

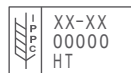

IPPC symbol, country code, registration number of the national plant protection authority, heat treatment on the left-hand corner block.

**CP9**  
095-8-01

CP type marking and EPAL ID number (licence number-year-month) on the central block.



EPAL control staples

## Handling

4-sided accessibility and high quality enable efficient handling during production, storage and transportation all the way along the supply chain. Compatible with all (conventional) standard load carriers, industrial trucks and warehouse systems. Use: As container pallet for casks and flexible intermediate bulk containers.

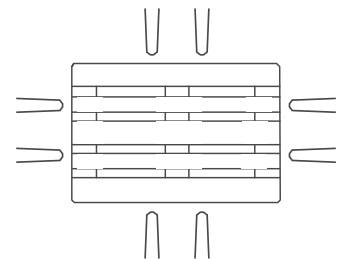

## Quality control



Quality is the key criterion for the reliable, safe deployment of EPAL CP pallets within the supply chain of international companies. EPAL CP pallets and EPAL pallets are the only ones around the globe which undergo regular independent quality inspections by one of the most renowned inspection companies in the world, Bureau Veritas.

## ISPM 15



Compliance with the ISPM 15 standard is an essential condition for the unrestricted use of load carriers in the international movement of goods. All EPAL CP pallets are therefore produced according to the stringent specifications of the IPPC and can thus be deployed around the globe. Local plant protection agencies will provide information on the countries that recognise the IPPC standard.

## Reconditioning/Repair



Damaged EPAL CP pallets can be reconditioned/repared cost effectively and in a climate-friendly manner by all EPAL-licensed pallet reconditioning/repair operations. EPAL CP pallets reconditioned/repared according to standard receive a repair control nail bearing the "EPAL" trademark and the licence number of the reconditioning/repair operation following the quality-assured reconditioning/repair.

## 1,140 mm Side

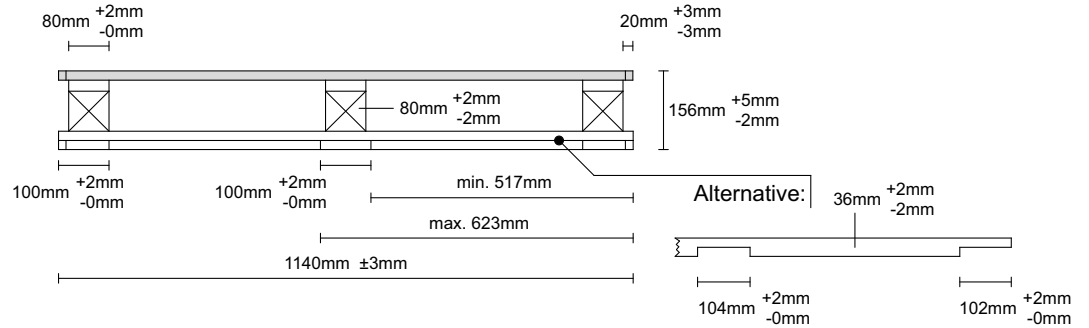

## 1,140 mm Side

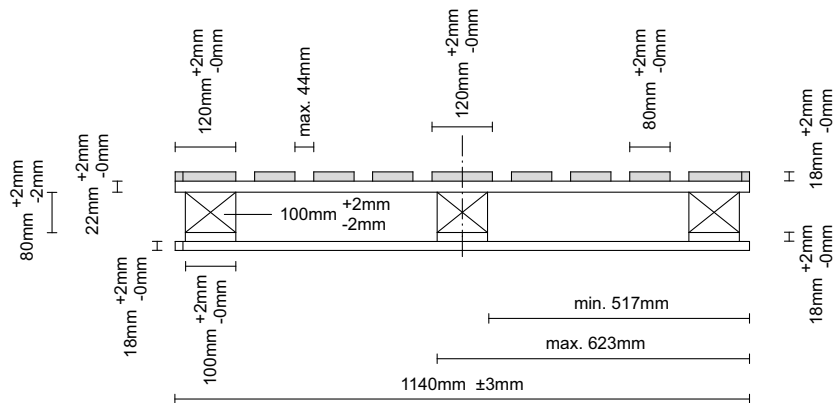

## Top view

